

R4718?S60

Bohrungen (5.5±0.05mm) in der Platine (1.5-1.6)mm für Rasthaken

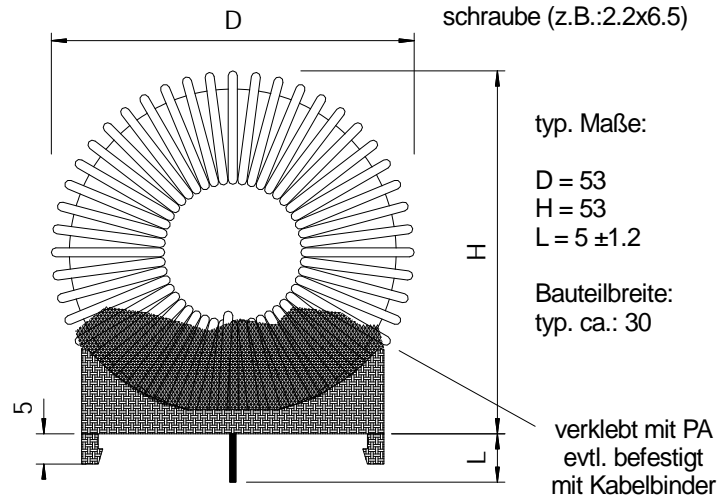

R4718?B60

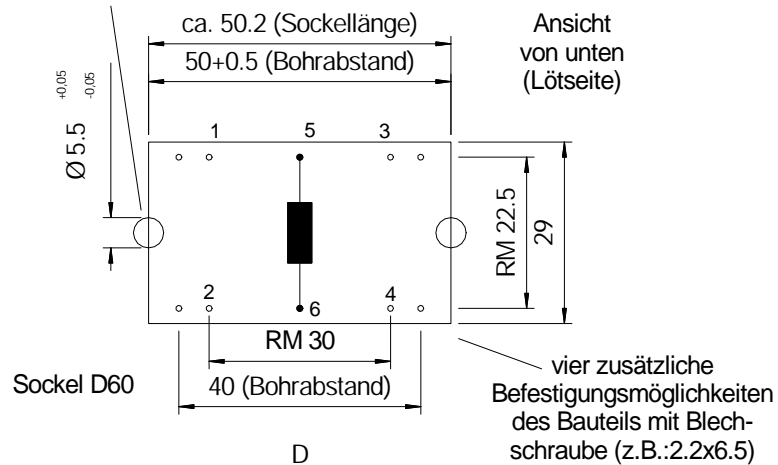
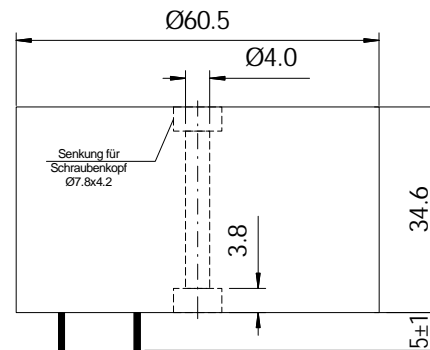
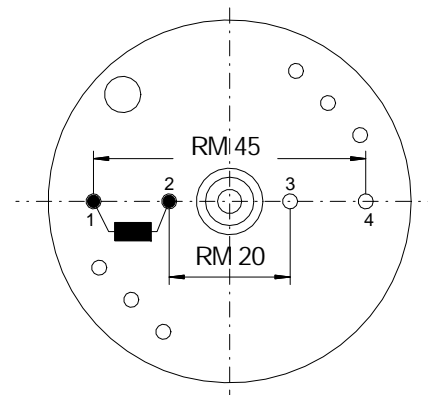

? = mögliche Materialien
A, C, D, F, K, L, M

R4718?11

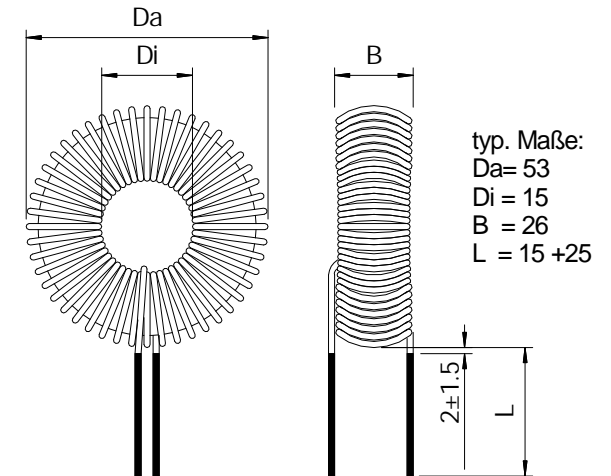

R4718?10

